

CLARUS 1™
SERIES II
Model 400 IA

CLARUS 1R™
SERIES II
Model 401 IA

CLARUS 2™
SERIES II
Model 402 IA

CLARUS 2R™
SERIES II
Model 403 IA

FOCUS 1™
Model 430 IA

FOCUS 1R™
Model 431 IA

FOCUS 2™
Model 432 IA

FOCUS 2R™
Model 433 IA

CLARUS SL™
Model 425 IA

CLARUS SL-R™
Model 426 IA

Acoustic Image®
Musical Amplification:
Setting The Standard

© 2004 Acoustic Image LLC



Clarus 1



Clarus 1R



Clarus 2



Clarus 2R



Focus 1



Focus 1R



Focus 2



Focus 2R



Clarus SL



Clarus SL-R

Owner's Manual

Integrated Amplifiers

Acoustic Image®
Musical Amplification:
Setting The Standard

Welcome to Acoustic Image!

Contents

Welcome	1
The Basics	1
Operation	2
Power	2
Preamp	2
Inputs	2
Controls	3
Control Panel Drawings	4
Signal Flow Diagram	5
Notch/High Pass Filter	6
Effects Loop	6
Direct Out	6
Reverb	6
Power Amp	7
Amp Placement	7
Care	8
Warranty Information	8
Specifications	9

The information in this manual is subject to change without notice. No part of this manual may be reproduced by mechanical, electronic or other means in any form without prior written permission from Acoustic Image.

The Acoustic Image logo is a registered trademark of Acoustic Image LLC. Contra, Contra R, Coda, Coda R, Contra EX and New Yorker are trademarks of Acoustic Image LLC

You have purchased a state-of-the-art musical instrument amplifier, combining purity, power and portability in a package that sets a new standard in high fidelity amplification.

Each of our designs is engineered to accurately reproduce the sound of acoustic and electric instruments, delivering flat frequency response across the entire musical spectrum; extended, tight, well-controlled bass; and complete clarity of sound reproduction.

This manual provides operating information for your Acoustic Image Clarus 1, Clarus 1R, Clarus 2, Clarus 2R, Clarus SL, Clarus SL-R, Focus 1, Focus 1R, Focus 2 or Focus 2R.

The Basics

All Acoustic Image integrated amplifiers are based on a superb class-D power amp that delivers 300 Watts into 2 ohms (Clarus amps), 350 Watts into 2 ohms (Clarus SL amps) or 600 Watts into 4 ohms (Focus amps) and on a sophisticated, sensitive preamplifier. The features of the preamp and the power amp configuration define the specific amp model.

The power amp is a high efficiency design that requires no external heat sinks or cooling fans and is capable of driving loads as low as 2 ohms (4 ohms for Focus amps). AC power and output speaker jacks are located on the rear of the enclosure. A standard, three-prong detachable AC power cord is used to provide power to the unit, while an AC voltage selection switch allows the unit to operate at 115V/60 Hz or 230V/50 Hz.

Depending on the model chosen, your preamp offers an instrument channel alone or instrument and microphone channels, with or without an 8-program digital reverb (the Clarus SL-R uses the same reverb with three program options). All of our preamps incorporate a four-band EQ per channel, high and low impedance instrument inputs (to optimize the sound of piezo-type pickups), an effects loop with return level control, and a selectable notch/high pass filter for feedback control and reduction of low frequency boominess--along with a direct out capability with ground lift and a master level control. The Clarus SL's do not have the return level control, notch/high pass filter or the direct out ground lift.

Yours is a high fidelity amplifier with full-range frequency response and low distortion and noise that will accurately amplify your sound. Onboard EQ is sufficient to overcome room acoustics and subtly shape the sound of your instrument. However, you should note that our amps are not designed to play at tonal extremes or with a distorted output. To achieve these, use an external effects box.

Operation

Power

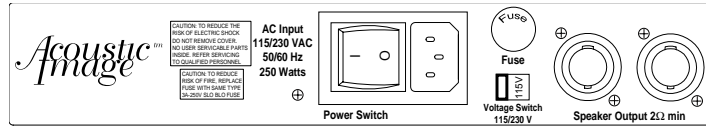

Clarus Rear Panel (the Focus and Clarus SL rear panels are similar).

Plug the detachable AC power cord into the receptacle on the back of the amp and into a wall receptacle. A power switch next to the AC connector turns on power to the pre- and power amps, illuminating a “power on” indicator on the front panel of the amp. A 3-amp slo-blo fuse (Clarus models) or 6.3 amp fast blo fuse is mounted on the back panel. To replace this, remove the AC cord and twist out the fuse holder. A spare fuse is included with this manual.

All amps will work with either 115 volt, 60 Hz AC or 230 volt, 50 Hz AC power. A switch located on the rear panel selects the appropriate voltage. Note that the correct AC power cord must be used for connection to the appropriate wall plug. If you do not have the right cord, you can buy one from an electronics or computer store. Be sure the switch is in the correct position for the intended application. **Operation at 230 volts with the switch in the 115 volt position will damage the unit.**

Preamp

Refer to the signal flow diagram (shown for the Clarus/Focus 2R--the other models have the same signal flow for the features equipped) and the control panel drawings for more information.

Inputs

The Clarus and Focus models both have an instrument channel with high (10 megohm) and low impedance (1 megohm) inputs, accessible using standard 1/4-inch plugs. The option is given in order to get the best sound from piezo pickups. Both inputs have the same gain through the amp. Which impedance is most appropriate for your particular instrument depends on pickup design. To decide, listen to the bass/treble balance as you change inputs. Typically, terminating in the higher impedance will raise the relative level of the bass frequencies. Magnetic pickups normally sound best with the low impedance input. **Don't be afraid to experiment to find the best sound for your ears. There are no set rules as to which input is best to use.**

If your preamp has two channels, the microphone channel is accessed using a standard XLR connector. Phantom power is available through the connector for powering a mic or outboard preamp and can be activated using the push button switch located next to the connector. To avoid an audible “pop”, set the mic input level control all the way off when switching on the phantom power.

The two instrument inputs are separately buffered. This allows you to plug two instruments into your amp and play them separately or together. This feature is useful when you are doubling on two instruments with different impedance requirements (for example, electric and acoustic guitar or bass). Plug the acoustic into the high Z input and the electric in to the low Z input. You can then play each instrument as needed without having to plug and unplug instruments.

With the two-channel models, the mic and instrument channels can be blended to mix a mic and pickup for best sound from one instrument or to mix vocals with an instrument. An adaptor can be used to convert the XLR to a 1/4 inch input if a second instrument channel is desired. However, when using an adaptor, the resulting input impedance is fairly low which limits the use of the channel to magnetic pickups. Using a piezo pickup with such a low impedance will likely result in poor sound quality.

Controls

The preamp has the following controls in each channel: input level, bass, mid, treble, brite and effects level. In addition, there is a variable frequency, selectable notch/high pass filter and a master level control. Note that the Clarus SL amps do not have the effects level control or the filter capability.

Level

The input level controls the level of the signal at the input stage of the preamp. The master volume controls the level of the signal at the output of the preamp (at the input of the power amp). Set the master control at “12 o'clock” and the input level at zero. The input level should then be used to control the overall output of the unit.

Tone

Each tone control has a center detent at the flat position. Experiment with settings to achieve the frequency balance that sounds best to you. In general, small values of boost and cut are best. The amp is designed with flat frequency response so only minor corrections should be required to compensate for room effects or “peaky” pickups in order to maintain the balanced response desired for acoustic instrument amplification. To minimize electronic noise, avoid operating all controls simultaneously at their maximum settings.

The bass control is a shelving-type that affects frequencies below 250 Hz and with a maximum boost/cut of 15 dB. The mid control affects frequencies between 300 Hz and 2000 Hz and has a maximum boost/cut of 15 dB. The treble control is also a shelving-type that affects frequencies above 1000 Hz with a maximum boost/cut of 15 dB. The brite control affects frequencies between 6,000 and 16,000 Hz and provides a maximum boost/cut of 15 dB.

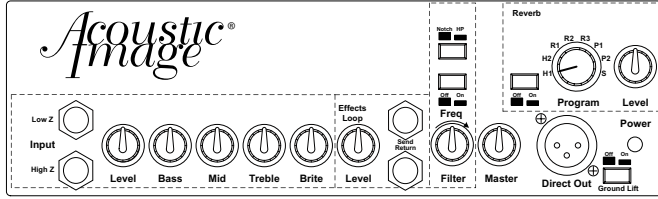
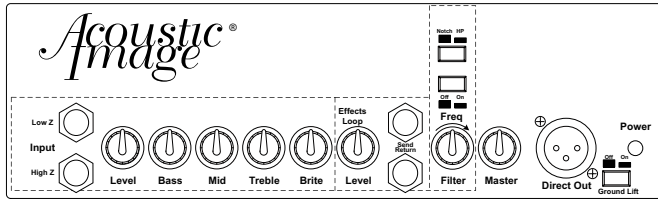

Clarus/Focus 1R Control Panels

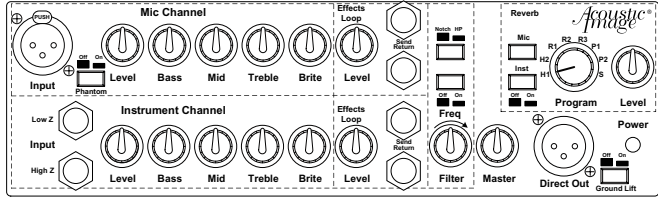
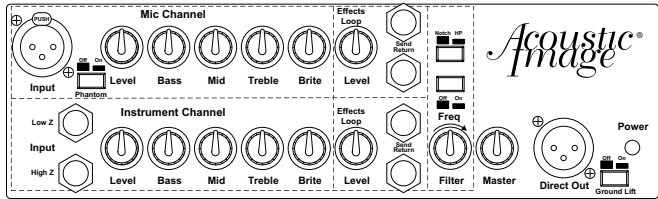

Clarus/Focus 2R Control Panels

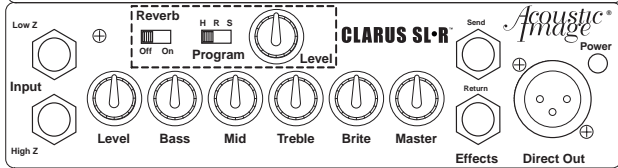
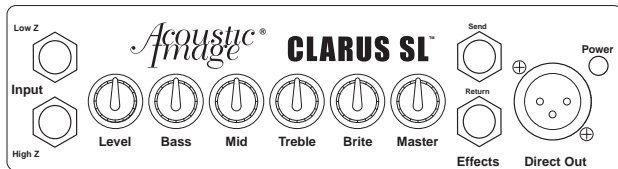

Clarus SL/SL-R Control Panels

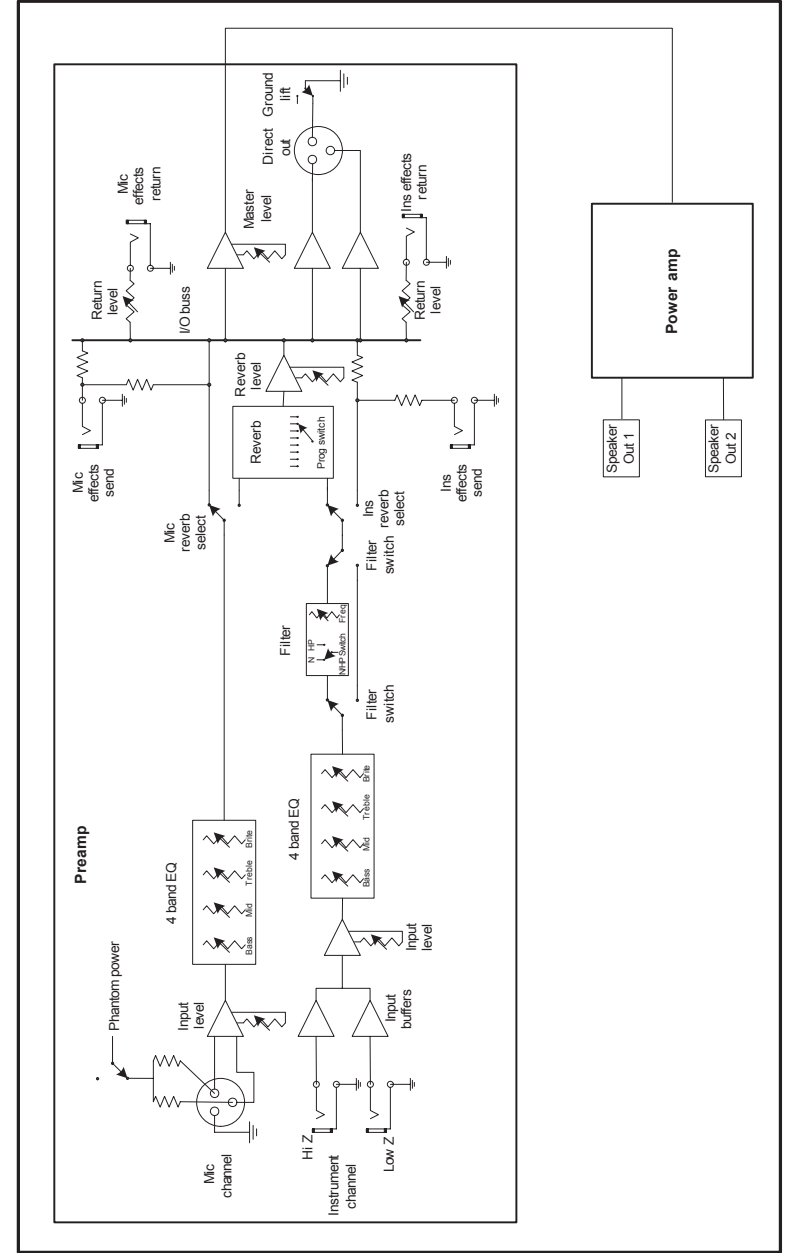

Signal Flow Diagram

Notch/High Pass Filter

The notch/high pass filter is a fixed amplitude, variable frequency type that inserts either an 18 dB cut or a 12 dB per octave rolloff at frequencies between 30 and 700 Hz, depending on the position of the control. The notch filter is used to remove a given feedback frequency to reduce feedback "howl". The high pass filter is used to reduce the bass output in cases where room location or instrument/pickup combination results in "boomy" sound. To use either, push the on/off switch to turn on the filter circuit then select the filter type using the notch/high pass switch. Start with the control fully counterclockwise and gradually turn it clockwise until the desired effect is achieved, then experiment with the position of the control to give you the sound you like best. The Clarus SL's do not have the filter capability.

Effects Loop

Acoustic Image preamps have output ("Send") and input ("Return") capability in each channel to allow you to use effects boxes. The send output is affected by the input volume and tone controls and can also be used as a preamp output for driving other power amplifiers. The Return input can be used to directly connect an external preamp to the unit's power amp. The effects level control in each channel controls the volume of the returned ("wet") signal relative to the original ("dry") signal. Because the effects loop is a parallel type, plugging something into the send output does not interrupt the signal path. So, a tuner can be plugged into the send output without affecting the signal going through the amp. When the effects loops are not used, the level controls should be set at zero. The Clarus SL's do not have the effects level control.

Direct Out

An XLR jack is provided for a Direct Out connection that allows the system's output to be fed to mixing boards of house PA systems or recording studios. As a result, the instrument amplified by the unit can be recorded or further amplified by the house PA system. In the two-channel amps, the Direct Out signal is the combined output of the mic and instrument channels and it is affected by the input level and tone controls of each channel (post EQ). Any reverb signal selected is also present in the direct out signal.

A ground lift switch is available to "lift" the ground from the output of the direct out—reducing noise should a ground loop create hum when the unit is connected to a mixing board. The Clarus SL's do not have the ground lift switch.

Reverb (Clarus/Focus 1R, Clarus/Focus 2R and Clarus SL-R only)

Our high-quality digital reverb units offer 8 program selections: 2 "Hall" (Concert Hall and Arena), 3 "Room" (Club, Chamber and Garage), 2 "Plate" reverb simulations (Plate and Vocal), and 1 "Spring" reverb simulation. The Clarus SL-R offers 3 program selections, Concert Hall, Club and Spring. With

the Clarus/Focus 2R, there are also switches to select which channel (mic or instrument) has reverb added. If both switches are closed, the selected reverb setting appears in both channels. A level control affects the level of the reverb signal that is mixed with the "dry" signal to control the overall effect of the reverb. You should experiment with both the reverb program selection and the level control to find the sound that you prefer. When reverb is not used, the switches for both channels should be off and the level control should be turned fully counterclockwise.

Power Amp

Speakers are connected to the amps via Neutrik Speakon connectors ("twist lock" type). These connectors are used because of their low contact resistance and non-shorting operation. The output of each Speakon connector is wired to pole "1". Make sure the cables you use to connect a speaker are similarly wired. Cables with Speakon connectors are available from Acoustic Image if you are unable to obtain them from your local music store. One Speakon to 1/4 inch cable is supplied with the unit.

The power amplifier is capable of driving speaker loads as low as 2 ohms (4 ohms for the Focus amps). Use a high quality speaker system in order to get the maximum performance from the amp. The Acoustic Image Contra EX is an excellent choice.

The power amp is short circuit protected. If a short is connected to one of the speaker jacks, the output signal will be interrupted until the short is removed. If there is an intermittent short, the output will be interrupted for about one second each time the short appears. However, the nature of a switching amplifier makes it difficult to protect against shorts in all circumstances. **To be on the safe side, you should shut off the power to the amp before connecting or disconnecting speakers from the unit.**

We highly recommend the use of Speakon connectors at both the amp and speaker ends of the connecting cable. If you use these connectors, you will get the highest possible performance and reliability from your amp. Conversion of your speaker to Speakon connectors is a simple job. Contact your local repair shop or Acoustic Image for more information.

All Acoustic Image amps can be operated without a speaker load if required. **When operating without a speaker attached, turn the master level to zero (all the way counterclockwise). This will prevent the power amp section of the amp from being driven and protect it from damage.**

Amp Placement

The small size and light weight of the amps allow them to be placed almost anywhere that is convenient for the performer. The best results will be achieved from the speaker/amp combination if the resistance of the speaker cable is kept as low as possible. That means that a shorter cable is better.

Care

The amp chassis is made of powder coated aluminum. A little caution in how it is handled will keep it looking new for years to come. Use a clean, dry cloth to clean the surfaces of the amplifier. Note that there are no user-servicable parts inside the amp. Refer servicing to qualified Acoustic Image or other technicians.

Warranty and Repair

We stand behind our products with a full warranty of five years from the date of purchase. Should a problem arise, please call us before returning your amplifier or enclosure. Naturally, our warranty does not cover products that have been damaged through misuse.

Warranty Information

Serial Number _____

Acoustic Image

7517 Precision Dr, Suite 102

Raleigh, North Carolina 27617

919-598-3113 (Phone)

919-957-3294 (Fax)

Web Site: www.acousticimg.com

Email: info@acousticimg.com

Specifications

System

Frequency Response	20 Hz - 20 kHz, ± 0.5 dB
Distortion	<0.5%, full output, <0.1%, typical
Hum and Noise	-85 dB or better
AC Power	115V/60 Hz or 230V/50 Hz, switchable
Size	10x9x2.5 inches (Clarus/Focus) 7.3x7.5x2.2 inches (Clarus SL/SL-R)
Weight	5 lbs (Clarus), 4 lbs (Focus), 40 oz (SL)

Preamp (Mic and Instrument Channels-as appropriate to model)

Mic Input	600 ohm balanced, XLR connector
Phantom Power	38 volts, on/off switch
Instrument Inputs	Low impedance (1 M Ω), High Impedance (10 M Ω), separately buffered
Direct Out	+4 dB, balanced, XLR connector, ground lift
Effects Loop	Parallel type with return level control
Bass Control	Shelving type, ± 15 dB at 60 Hz
Mid Control	± 15 dB at 650 Hz
Treble Control	Shelving type, ± 15 dB at 10 kHz
Brite Control	± 15 dB at 9 kHz
Notch Filter	>-18 dB sweepable from 30 to 700 Hz
High Pass Filter	-12 dB/octave sweepable from 30 to 700 Hz

Reverb (Clarus/Focus 1R/2R, Clarus SL-R only)

Type	Digital with 8 presets and level control
Reverb Presets	2 Hall (Concert Hall, Arena), 3 Room (Club, Chamber, Garage), 2 Plate (Plate, Vocal) and 1 Spring. Clarus SL-R has Concert Hall, Club, and Spring only

Power Amp (all models)

Topology	Class D (PWM)
Switching Frequency	280 kHz, 200 kHz for Focus models
Output Power	>200 W @ 4 Ω , >300 W @ 2 Ω (Clarus) >250 W @ 4 Ω , >350 W @ 2 Ω (Clarus SL) >350 W @ 8 Ω , >600 W @ 4 Ω (Focus)
Minimum Load	2 Ω (Clarus and SL), 4 Ω (Focus)
Output Connectors	Neutrik Speakon type (pole 1)

Included Accessories	Gig bag with shoulder strap, 6 foot Speakon to 1/4 inch cable
-----------------------------	---